

| | |
|-------------|--|
| Seat No. | |
|-------------|--|

[5352]-502

S.E. (Civil) (First Semester) EXAMINATION, 2018
STRENGTH OF MATERIAL
(2015 PATTERN)

Time : Two Hours**Maximum Marks : 50**

N.B. :- (i) Q. Nos. 1 or 2, Q. Nos. 3 or 4, Q. Nos. 5 or 6 and Q. Nos. 7 or 8.

(ii) Neat sketches must be drawn wherever necessary.

(iii) Figures to the right indicate full marks.

(iv) Assume suitable data, if necessary.

(v) Use of electronic pocket calculator is allowed.

(vi) Use of cell phone is prohibited in the examination hall.

1. a) A stepped bar is subjected to axial forces as shown in fig.1 Determine the total deformation of the bar. Take $E_1 = E_2 = E_3 = 200\text{GPa}$

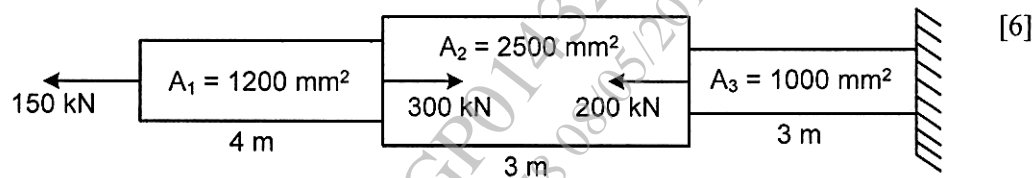

Fig.1

- b) A groove $40\text{ mm} \times 40\text{ mm}$ is cut symmetrically at the bottom of a rectangular beam section as shown in fig.2. If the tensile stresses shall not exceed 25 N/mm^2 , Find the safe uniformly distributed load which the beam can carry on a simply supported beam of a span 4 m . (All dimensions are in mm)

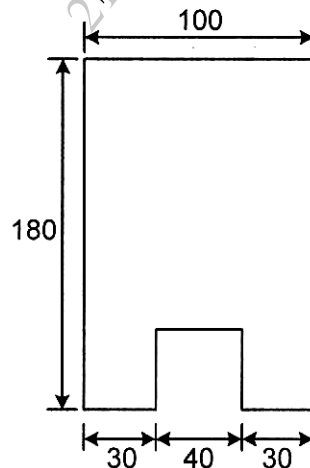

Fig.2

P.T.O.

OR

2. a) A steel rod 20 mm diameter and 6 m long is connected to two grips one at each end a temperature of 120°C . Find the pull exerted when the temperature falls to 40°C .
i) If the ends do not yield
ii) If the ends yield by 1.10 mm. Take $E = 2 \times 10^5 \text{ N/mm}^2$ and $\alpha = 1.2 \times 10^{-6} / ^{\circ}\text{C}$. [6]
- b) An I section has the following dimensions. Web: 300 mm \times 10 mm, Flange: 150 mm \times 20 mm. The beam is subjected to a shear force of 44 kN. Draw the shear stress distribution diagram over the depth of the section. [6]
3. a) If a solid steel shaft that will not twist through more than 3° in a 6 m length when subjected to a torque of 10kN.m, Find the minimum diameter of the shaft and maximum shear stress developed. $G = 83 \text{ GPa}$. [6]
- b) A shaft of 95 mm diameter transmits 300 kW power at 150 rpm. If at a section, bending moment is 20 kN.m. Find the principal stress and maximum shear stress. [6]

OR

4. a) Using the equation of strain energy, derive the stress intensity due to the following [6] types of axial loading.
i) Gradually applied load
ii) Suddenly Applied load
- b) A hollow steel shaft 4 m long transmits a torque of 25 kN.m. The total angle of [6] twist in this length is limited to 2.5° and the allowable shearing stress is 90 MPa. Find out the outside and inside diameter of the shaft if $G=85 \text{ GPa}$.
5. a) A simply supported beam of span 5 m, intensity of loading increases uniformly [6] from 8 kN/m at one end to 16 kN/m at the other end as shown in fig.3. Find the position and magnitude of the maximum bending moment. Also Draw Shear Force & Bending Moment Diagram.

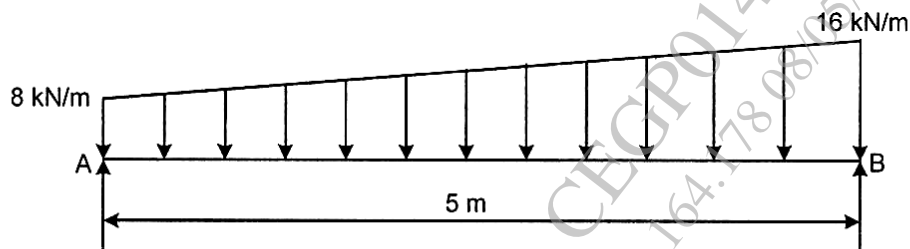

Fig.3

- b) Draw the loading diagram & bending moment diagram from the given shear force [7]
diagram of a beam as shown in fig.4

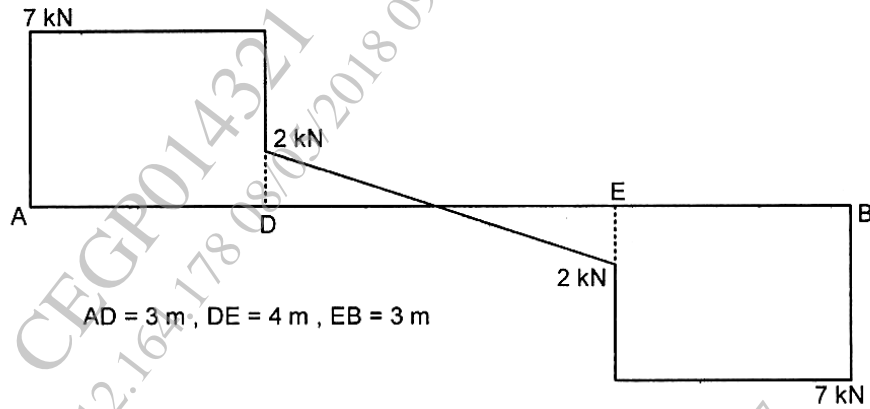

Fig.4

OR

6. a) Draw Shear Force Diagram & Bending Moment Diagram for the overhanging [6]
beam carrying loads as shown in fig.5. also locate point of contra flexure.

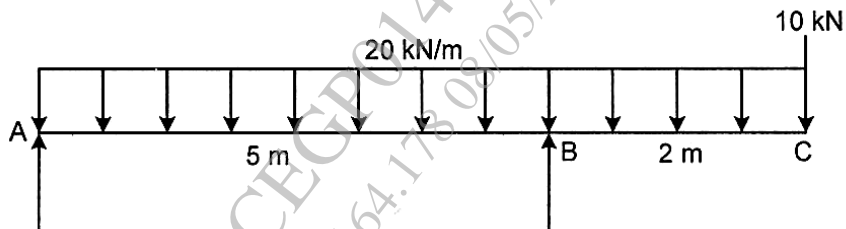

Fig.5

- b) Construct loading diagram for the following shear force diagram for a beam as [7]
shown in fig.6.

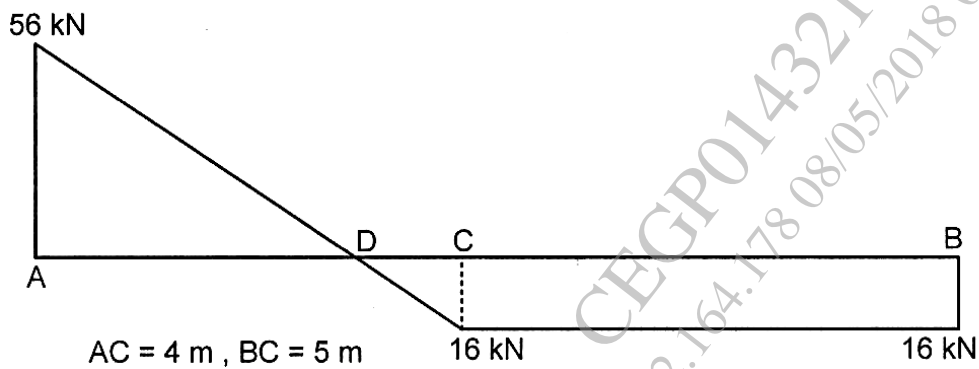

Fig.6

7. a) A hollow alloy tube 5 m long with external and internal diameters equal to 40 mm and 25 mm respectively was found to be 6.4 mm under a tensile load of 60 kN. Find the buckling load for the tube, when used as a column with both ends pinned. Also find the safe compressive load for the tube, with a factor of safety 4. [6]
- b) State the assumptions made in Euler's theory and its limitations. [7]

OR

8. a) Define core of section and hence obtain core of section for a rectangular column of breadth 480 mm \times depth 120 mm. [6]
- b) A short masonry pillar 600 mm \times 600 mm in section. The pillar carries an eccentric load of 1000 kN acting at an eccentricity of 80 mm from the longitudinal axis as shown in fig.7 . Find the maximum and minimum stresses on the section. [7]

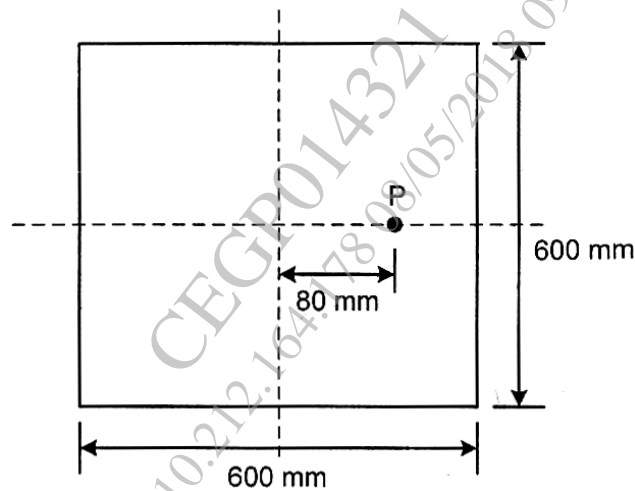

Fig.7